



# Installation and Troubleshooting Guide



NOTE: This installation is to be completed by an Authorized Dealer or Professional Service Technician. For questions regarding installation or warranty, call CDI Tech Support at 866-423-4832. **Do not return to the Dealer or Distributor where the part was purchased. Contact CDI Electronics Directly for Return Material Authorization.**

## CDI P/N: 114-4796 Switch Box 3 Cylinder

This unit replaces 332-4796A 3 and A6.

**WARNING!** This product is designed to be installed by a professional marine mechanic. CDI Electronics cannot be held liable for injury or damage resulting from improper installation, abuse, neglect or misuse of this product. **The acceptable voltage range for battery type ignitions is typically 9.5 Volts (at cranking) to a maximum of 16 volts at full throttle (13.2-14.6 preferred). Voltages above or below this range can cause damage to the CD. NO RPM LIMITER.**

**DO NOT USE A MAINTENANCE FREE, DRY CELL OR AGM BATTERY WITH ANY BATTERY DRIVEN CD UNIT!**

### INSTALLATION

1. Disconnect the negative battery cable.
2. Check and clean all battery terminals and engine grounds.
3. Disconnect all wires, unbolt and remove the old CD.
4. Remove the high tension lead from the original coil and distributor cap.
5. Reconnect the red wire (that went to the old CD) to the rectifier battery terminal (or tape off) as it is no longer needed.
6. Clip off the ring terminals from the white wire coming from the ignition and the blue, white/black and black trigger wires.
7. Strip the insulation from approximately the last 3/16" of the wire ends, and twist the bare wire so that it does not fray out.
8. Slide the insulator sleeves on the wires from the trigger and the white wire from the harness. Crimp and solder the bullet connectors on the white harness wire and the trigger wires.
9. Connect the new high tension lead from the distributor to the new mounted coil on the plate. **WARNING: DO NOT CONNECT THIS CDI MODULE TO THE OEM COIL AS SEVERE DAMAGE TO THE CDI UNIT WILL RESULT.**
10. Install the new CDI module using the bolts and nuts supplied.
11. Connect the white wire from the harness to the white wire from the new switch box.
12. Connect the white/black, black and blue trigger wires to the new switch box, matching the wire colors.
13. This switchbox does not have a tachometer output. The brown wire from the harness to the switchbox was for a *two-wire* tachometer (no longer available). Therefore, tape off the brown wire unless you install a newer style tachometer (which will connect to the rectifier).
14. Reconnect battery cable.
15. While monitoring the battery voltage, start and run the engine. With a fully charged battery, run the engine on a dynamometer or on the water and bring the engine to WOT (wide open throttle). If the battery voltage exceeds 16 volts after a short time, try a different brand of battery. Battery voltage should be checked at the battery and at the ignition pack. Voltage above 16 volts or below 9-1/2 volts will damage the ignition pack.

**NOTE:** When you turn the ignition on, you may hear a high pitched whining noise coming from the CDI module. This is normal and varies depending upon the battery voltage.

### TROUBLESHOOTING

#### NO SPARK:

1. Connect a spark gap tester to the spark plug wires and check for fire on *all cylinders*. If some cylinders fire and not others, the problem is likely in the distributor cap, rotor button or spark plug wires. **Notice:** If the unit only fires when you let off of the key switch, the trigger is usually the problem.
2. Disconnect the mercury tilt switch and retest. If the ignition works properly, replace the mercury switch.
3. Connect a spark gap tester to the high tension lead coming from the ignition coil and set it to approximately 7/16". If you have spark when you crank the engine over, there is a problem in the distributor cap, rotor button or spark plug wires. **Notice:** If the unit only have spark when you let off of the key switch, the trigger is usually the problem.
4. Check voltage present on the white wire at cranking. It **MUST** be at least 9½ volts. If not, check the harness, key switch, starter or battery. (Remember to check polarity).
5. Check the voltage present on the white/black wire at cranking. It **MUST** be at least 9 volts. If the voltage is low on this wire (but is correct on the white wire form the harness), the problem is likely in the pack.
6. Check DVA voltage on the green wire going to the coil. It should be approximately 200 volts at cranking.
7. Disconnect the blue, black and white/black trigger wires and connect a jumper wire from the white/black wire to the black wire. Connect another jumper to the blue wire and (with the key switch turned on) strike the jumper against engine ground. The unit should spark each time. If it does, the CD module is usually good. See the following diagram for jumper test connections:

NOTE: This installation is to be completed by an Authorized Dealer or Professional Service Technician. For questions regarding installation or warranty, call CDI Tech Support at 866-423-4832. **Do not return to the Dealer or Distributor where the part was purchased. Contact CDI Electronics Directly for Return Material Authorization.**

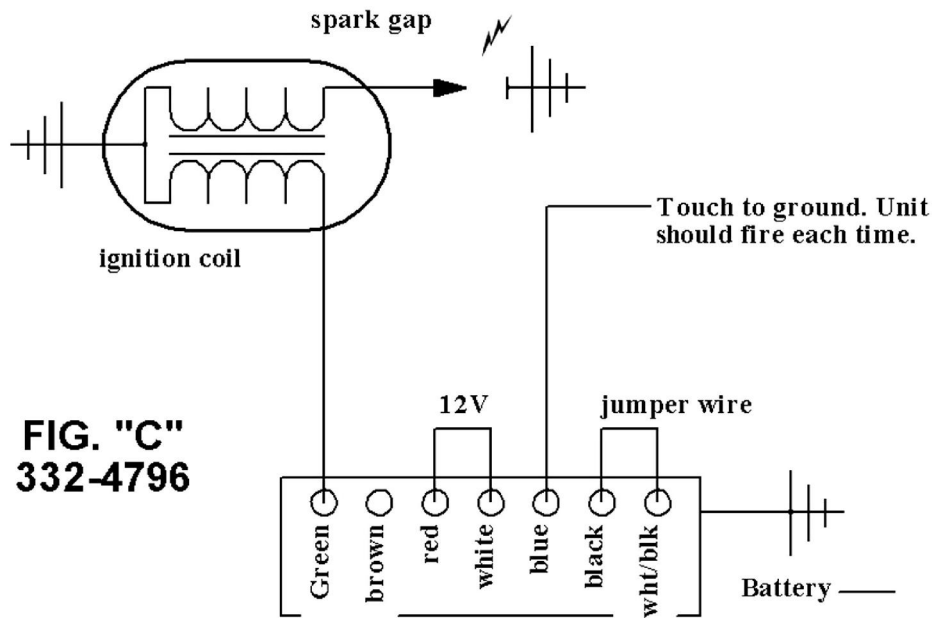

**FIG. "C"  
332-4796**

### ONLY HAS SPARK AS LONG AS THE STARTER IS ENGAGED:

This symptom usually indicates a bad trigger or low voltage.

### NO SPARK OR INTERMITTENT SPARK ON ONE CYLINDER:

Note: A CD Tester like the one by CDI Electronics or Merc-o-Tronic can be used to test the CD module, distributor cap, rotor button and spark plug wires on the engine while the Trigger Tester by CDI can be used to test the distributor trigger.

1. Connect a spark gap tester to the high-tension leads coming from the distributor cap and set the gap to approximately 7/16". (Use of a CD Tester is recommended).
2. Align the rotor with #1 spark plug wire. Disconnect the trigger wires and connect a jumper wire from the brown trigger terminal to the white trigger terminal.
3. Connect another jumper wire to the black trigger terminal turn the ignition switch on. Strike the jumper wire from the black terminal against engine ground – (DO NOT HOLD THE JUMPER AGAINST ENGINE GROUND). Only the #1 spark plug wire should fire. If any other spark plug wire has fire, there is a problem in the distributor cap.
4. Repeat the test for the other cylinders.

### HIGH SPEED MISS:

1. Check the battery voltage on the red and white terminals of the switch box at high speed, the voltage should be between 12.5V and 16V DC. A reading outside this range will damage the CD module. If the readings are abnormal, perform the voltage drop test described above.
2. Perform a high-speed shutdown and read the spark plugs. Check for water. A crack in the block can cause a high miss at high speed when the water pressure gets high, but a normal shutdown will mask the problem.

NOTE - Perform a voltage drop test after the engine is repaired to see if there is a problem with the voltage going to the CD module. At cranking and while the engine is running, use a DC voltmeter and put the black meter lead on the battery POS (+) *post* and the red meter lead on the positive battery cable at the starter solenoid. Keep the black lead on the battery post and shift the red meter lead to the positive post of the rectifier, then to the red and white terminals on the switch box. If you find a reading above 0.6V, there is a problem at the point where the voltage jumped up. For example, if the meter reads 0.4V until you get to the white terminal and then jumps to 2.3V on the white terminal –this indicates a problem in the key switch, or harness. Repeat the test for the negative battery post by putting the black meter lead on the battery NEG (-) *post* and the red meter lead on the negative battery cable terminal, then shifting to the engine