



Installation and Troubleshooting Guide



NOTE: This installation is to be completed by an Authorized Dealer or Professional Service Technician. For questions regarding installation or warranty, call CDI Tech Support at 866-423-4832. **Do not return to the Dealer or Distributor where the part was purchased. Contact CDI Electronics Directly for Return Material Authorization.**

CDI P/N: 144-7169 Timing Protection Module (TPM) 6 Cyl.

NOTE: This TPM Controller can replace the 857169T 1 and 857169T 2 Controllers on Fuel Injected Engines.

This product is designed for installation by a professional marine mechanic. CDI cannot be held liable for injury or damage resulting from improper installation, abuse, neglect or misuse of this product.

INSTALLATION

1. Disconnect the 6 pin trigger connector, 6 Pin CDM harness and the 8 pin power/warning harness.
2. Remove the old TPM Module Controller and clean all ground wires and mounting plate.
3. Check all connectors, terminals and wires for corrosion, breaks and broken insulation.
4. Using the original screws, mount the new TPM Module Controller to the engine, making sure no wires are pinched during the installation.
5. Lubricate the seals for the 6 pin trigger connector, 6 Pin CDM harness and the 8 pin power/warning harness using a good quality dielectric grease.
6. Connect the 6 pin trigger connector, 6 Pin CDM harness and the 4 pin power/warning harness.
7. Connect the Black ground wire to a clean engine ground.

TROUBLESHOOTING

NO SPARK OR WEAK SPARK ON ALL CYLINDERS:

1. Disconnect the Black/Yellow Kill wire and retest for spark. If spark returns, the kill circuit is shorted.
2. Disconnect the yellow wires from the stator to the rectifier and retest. If the engine fires, replace the rectifier.
3. Check the cranking RPM. A cranking speed less than 250-RPM will not allow the system to fire properly.
4. Check the connections from the stator, TPM Controller, trigger and engine grounds to make sure they are clean, free of corrosion and tight.
5. Disconnect the 6 pin connector from the trigger and the CDM harness. Then connect them together, bypassing the TPM Module Controller.
 - A) If spark returns, check the Purple wire to the TPM Module Controller. With the key switch on, you should have battery voltage present. If the voltage is not present, trace the Purple wire back to the key switch and locate the break.
 - B) If the spark does not return, check the stator
6. Disconnect one CDM module at a time and see if the other modules start firing. If they do, the module you just unplugged is bad.
7. Check the stator resistance and DVA output as given below:

Read from	Read to	Ohms	DVA (Connected)	DVA (Disconnected)
White/Green (Stator)	Green/White (Stator)	380-430 Ω	160-400 V	200-400 V

8. Check the resistance of the CDM's as follows (CDI P/N 934-0006 Test Harness make this easier):

	Red Meter Lead	Black Meter Lead	OEM Reading	CDI Reading
CDM Pin #	(A) Ground	(C) Trigger	1.2-1.4K Ω	1.2-1.4K Ω
CDM Pin #	(D) Stator	(A) Ground	Open*	Open*
CDM Pin #	(A) Ground	(D) Stator	Diode Reading*	Diode Reading*
CDM Pin #	(D) Stator	(B) Kill Circuit	Diode Reading*	Diode Reading*
CDM Pin #	(B) Kill Circuit	(D) Stator	Open*	Open*
CDM Pin #	(A) Ground	(B) Kill Circuit	Diode Reading*	Diode Reading*
CDM Pin #	(B) Kill Circuit	(A) Ground	High M Ω or Open*	High M Ω or Open*
-	High Tension Lead	(A) Ground	0.7-1.3K Ω	2.2-2.4K Ω

Diode readings are to be read one way, then reverse the leads and read again. You should get a low reading in one direction and a higher reading in the other.

*** This Measurement is with the meter set to the diode scale. Where you see the term "Reading" represents a value on the meter. Where you see the term "Open" represents no value showing on the meter.**

NOTE: This installation is to be completed by an Authorized Dealer or Professional Service Technician. For questions regarding installation or warranty, call CDI Tech Support at 866-423-4832. **Do not return to the Dealer or Distributor where the part was purchased. Contact CDI Electronics Directly for Return Material Authorization.**

9. Using a set of piercing probes, check the trigger Resistance and DVA output as given below:

Wire Color	Check	OEM Ohms	CDI Ohms	DVA Connected	DVA Disconnected
Purple wire	Blue	1.11 K -1.4K Ω	0.8 K -1050 Ω	0.4 V or more	4 V or more
White wire	Red	1.11 K -1.4K Ω	0.8 K -1050 Ω	0.4 V or more	4 V or more
Brown wire	Yellow	1.11 K -1.4K Ω	0.8 K -1050 Ω	0.4 V or more	4 V or more

10. Using a set of piercing probes, check the trigger voltage going to the CDM's:

Wire Color	Check to Wire Color	OEM Ohms	CDI Ohms	DVA Reading
Purple wire	Engine GND	Open	Open	0.2V to 2V
White wire	Engine GND	Open	Open	0.2V to 2V
Brown wire	Engine GND	Open	Open	0.2V to 2V
Blue wire	Engine GND	Open	Open	0.2V to 2V
Red wire	Engine GND	Open	Open	0.2V to 2V
Yellow wire	Engine GND	Open	Open	0.2V to 2V

NOTE: If the voltage is low, check the trigger resistance. If it is high, check the CDM and ground connections.

11. The connection guide below will assist you in locating areas where problems can occur. Remember a short in either #1, #2 or #3 can cause either # 4, #5 and #6 not to have spark.

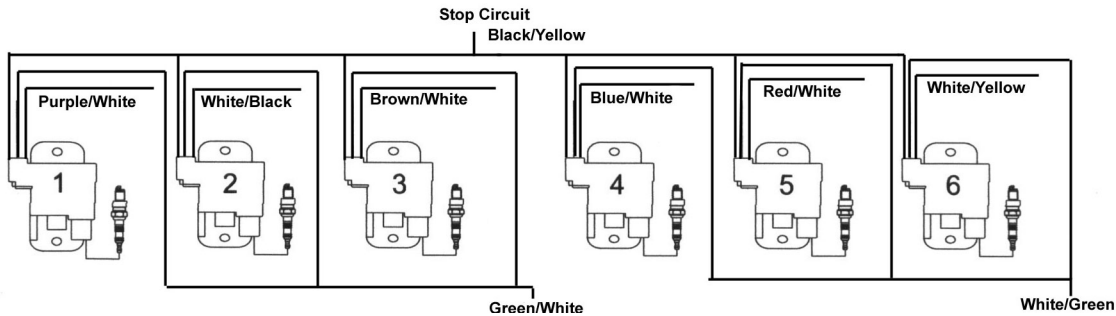

12. Replace the CDM Modules one at a time until the defective CDM Module(s) are identified.

NO SPARK OR INTERMITTANT SPARK ON ONE CYLINDER:

- Connect a CDM Test Harness (CDI P/N: 511-5207A 1) to the mis-firing CDM module.
 - Check the trigger DVA voltage on the mis-firing CDM module. You should have between 0.2 and 2 volts. If the voltage is low, check the trigger resistance. If it is high, check the CDM and ground connections.
 - Check the DVA voltage on the stator connection at the CDM. You should have 160-320 Volts.
- Swap the CDM on the cylinder that is mis-firing with a cylinder having good fire. If the problem moves, replace the defective CDM.
- Bypass the controller's trigger connector (connect the 6 pin connector from the trigger directly to the harness going to the CDMs. If spark returns on all Cylinders, replace the TPM Control Module as the Module is likely defective.

NO SPARK OR INTERMITTANT SPARK ON TWO CYLINDERS:

- Swap one of the CDMs that is mis-firing with a cylinder having good spark. If the problem moves, replace the defective CDM.
- If the mis-firing cylinders are split between the left three cylinders and the right three cylinders, check the trigger resistance and DVA output. Remember the trigger is paired to cylinders (1 to 4, 2 to 5, 3 to 6).
- Check the trigger DVA voltage on the mis-firing CDM modules. You should have 0.2 volts or higher.
- Replace the TPM Control Module with another one to see if the Module is defective.

NO SPARK OR INTERMITTANT SPARK ON THREE CYLINDERS:

- If the mis-firing cylinders are either the top three cylinders or the bottom three cylinders, disconnect the CDM Modules having good spark, one at a time and see if fire returns on the remaining CDMs. If so, replace the CDM Module you just disconnected.
- Swap one of the CDMs that is mis-firing with a cylinder having good spark. If the problem moves, replace the defective CDM.



Installation and Troubleshooting Guide



NOTE: This installation is to be completed by an Authorized Dealer or Professional Service Technician. For questions regarding installation or warranty, call CDI Tech Support at 866-423-4832. **Do not return to the Dealer or Distributor where the part was purchased. Contact CDI Electronics Directly for Return Material Authorization.**

ENGINE HAS ERRATIC TIMING OR ADVANCED TIMING:

1. Check the trigger magnet in the flywheel to see if it is loose or cracked.
2. Disconnect the 4 wire Detonation Controller and check the DVA voltage on the Black/White wire, reference to engine ground. You should read between 25 and 40 volts. If the voltage is low, replace the TPM Control Module.
3. Replace the TPM Controller.

ENGINE HARD TO SHIFT INTO OR OUT OF GEAR:

Check the Bias DVA voltage on the Black/White wire, reference to engine ground. If the voltage is low, replace the TPM Control Module.

RPM	DVA
Idle to 2500	2 – 8 V
2500 and up	25 – 40 V

ENGINE MIS-FIRES OVER 2500 RPM:

1. Connect a CDM Test Harness (CDI P/N: 511-5207A 1) to the CDM modules and check the DVA voltage from the stator and trigger.
 - A) You should have between 160 and 320 volts on the stator. If the voltage is low, check the stator resistance. If it is high, check the CDM and ground connections.
 - B) The trigger should read between 2 and 8 volts. If the voltage is low, check the trigger resistance. If it is high, check the CDM and ground connections.

NOTE: If the stator read low on three cylinder and they share the same color code, swap the stator wires and retest. If the problem moves, replace the stator. If the problem stays on the same CDMs, one of them is defective.
2. Check the DVA voltage on the Black/White wire, reference to engine ground. You should read between 2 – 8 V at Idle to 2500 RPM and 25 V to 40 V over 2500 RPM. If the voltage is low, replace the TPM Control Module.

ENGINE DOUBLE FIRING:

1. Verify the Black ground wire is making good connection to engine ground.
2. Check the Bias DVA voltage on the Black/White wire, reference to engine ground. You should read between 25 V - 40 V DVA over 2500 RPM. If the voltage is low, replace the TPM Control Module.
3. Swap the CDM that is double-firing with another CDM firing cleanly. If the problem moves, replace the defective CDM.

FUEL INJECTORS NOT ACTIVATING:

1. Check the DVA voltage on the Green, Green/White and Green/Red wires, reference to engine ground at cranking speed. You should read at least 8 volts. If the voltage is low, check the voltage on the Purple wire going to the Controller, you should read above 10 volts while cranking the engine.
2. Check the voltage going to the fuel injectors, you should read above 10 volts while cranking the engine.
3. Check the DVA voltage across the fuel injectors, if you see approximately 25-60 volts, the injectors are pulsing. You may have stopped up injectors.