

CDI Electronics®

Four Cylinder Engines

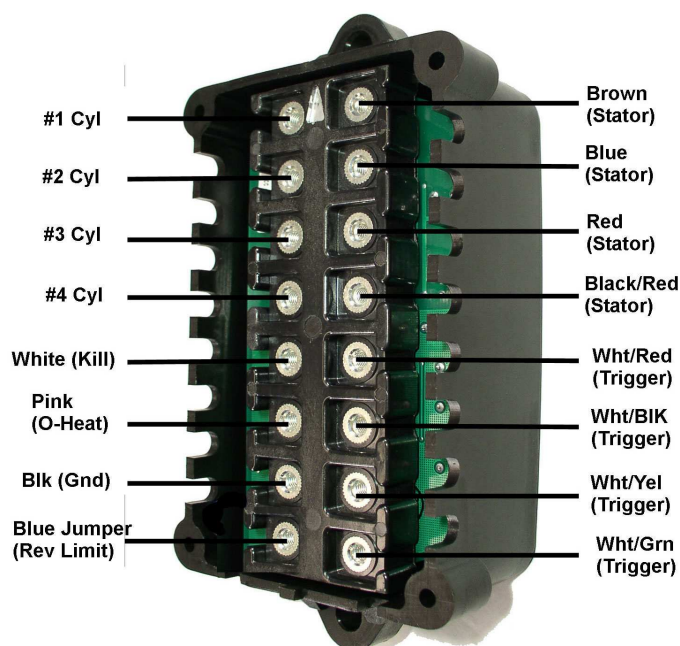

NO SPARK ON ANY CYLINDER:

1. Disconnect the White stop wire and retest. If the engine's ignition now has spark, the stop circuit has a fault. Check the key switch, harness and shift switch.
2. Check the resistance and DVA output of the Stator and Trigger:

Read from	Read to	OEM Reading	CDI Reading	DVA (connected)
White/Red Trigger wire	White/Yellow Trigger wire	280-430 ohms	280-430 ohms	2.5 Volts Minimum
White/Black Trigger wire	White/Green Trigger wire	280-430 ohms	280-430 ohms	2.5 Volts Minimum
Brown Stator wire	Red Stator wire	840-1260 ohms	600-800 ohms	85 Volts Minimum
Blue Stator wire	Black/Red Stator wire	65-130 ohms	10-20 ohms	16 Volts Minimum

3. Check the cranking RPM. A cranking speed of less than 250-RPM will not allow the system to spark properly. This can be caused by a weak battery, dragging starter, bad battery cables or a mechanical problem inside the engine properly.

NO SPARK OR INTERMITTENT SPARK ON ONE OR MORE CYLINDERS:

1. Check the resistance and DVA output of the Stator and Trigger:

Read from	Read to	OEM Reading	CDI Reading	DVA (connected)
White/Red Trigger wire	White/Yellow Trigger wire	280-430 ohms	280-430 ohms	2.5 Volts Minimum
White/Black Trigger wire	White/Green Trigger wire	280-430 ohms	280-430 ohms	2.5 Volts Minimum
White/Red Trigger wire	Eng Ground	Open	Open	2.5 Volts Minimum
White/Black Trigger wire	Eng Ground	Open	Open	2.5 Volts Minimum
White/Yellow Trigger wire	Eng Ground	Open	Open	2.5 Volts Minimum
White/Green Trigger wire	Eng Ground	Open	Open	2.5 Volts Minimum
Brown Stator wire	Red Stator wire	840-1260 ohms	600-800 ohms	85 Volts Minimum
Brown Stator wire	Eng Ground	Open	Open	85 Volts Minimum
Red Stator wire	Eng Ground	Open	Open	85 Volts Minimum
Blue Stator wire	Black/Red Stator wire	65-130 ohms	10-20 ohms	16 Volts Minimum
Blue Stator wire	Eng Ground	Open	Open	16 Volts Minimum
Black/Red Stator wire	Eng Ground	Open	Open	16 Volts Minimum

2. Check the DVA output on the Black/White wires from the power pack while connected to the ignition coils. You should have a reading of at least 125V or more. If the reading is low on one cylinder, disconnect the wire from the ignition coil for that cylinder and reconnect it to a load resistor. Retest. If the reading is now good, the ignition coil is likely bad. A continued low reading indicates a bad power pack or trigger (test per above).

ENGINE WILL NOT ACCELERATE ABOVE APPROXIMATELY 2000 RPM:

1. Verify the engine is not overheating and causing the power pack to limit the RPM.
2. Disconnect the Pink wire from the power pack and retest. If the engine now performs correctly, check the overheat sensor, oil level in the oil tank mounted on the engine and the wiring harness.
3. Check the position of the Pink wire and make sure it is not next to a spark plug wire.

CDI Electronics®

ENGINE WILL NOT ACCELERATE ABOVE APPROXIMATELY 2500 RPM:

1. Using an inductive tachometer, check the RPM on all cylinders. A difference in readings between the individual cylinders can be caused by a bad coil, power pack or spark plug.
2. If all cylinders show the same RPM and the engine will only rev to approximately 2500 RPM, check the running stator DVA output from idle thru WOT. You should show a steady increase in voltage on the Blue to the Black/Red stator wires throughout the RPM range. A drop in voltage can be the result of a bad stator coil or a bad regulator/rectifier (disconnect the Green wires to the regulator/rectifier and retest – if the engine now performs OK, the regulator/rectifier is likely bad).

MISS AT ANY RPM:

1. Verify the engine is not overheating and causing the problem.
2. Using an inductive tachometer, check the RPM on all cylinders. A difference in readings between the individual cylinders can be caused by a bad coil, power pack or spark plug.
3. Disconnect the Green wires to the regulator/rectifier and retest – if the engine now performs OK, the regulator/rectifier is likely bad.

S.A.F.E. WILL NOT ENGAGE:

Disconnect the Pink warning wire from the power pack. Connect a jumper wire to engine ground and connect it to the terminal where the Pink wire goes. If the engine now limits at approximately 2000 RPM, check the wiring from the temperature sensor and oil tank to the power pack. If it still fails to engage, the power pack is likely bad.

ENGINE WILL NOT STOP:

Disconnect the White stop wire and connect a jumper wire to engine ground. If you still have spark, the power pack is likely bad. If the engine has no spark with the jumper connected, either the wiring harness, keyswitch or emergency stop switch is bad.

