



# Installation and Troubleshooting Guide

All rights reserved. Reproduction or use of content, in any manner, without express written permission by CDI Electronics, Inc., is prohibited.

CDI P/N: 176-3095

This stator replaces P/N's 658095, 663095, 663095-1, 663095-2, 663095-3, 663095-4, 695095, 694095, 694095-1, 694095-2, 721095, 722095, 300-888793, 300-F658095, 300-F663095, 300-F694095-2, 300-F695095 and 300-F722095 (2, 3, 4 and 5 cylinder with crow's foot connectors).

**Warning!** This product is designed for installation by a professional marine mechanic. CDI cannot be held liable for injury or damage resulting from improper installation, abuse, neglect or misuse of this product.

**NOTICE!!** This stator has been redesigned to enhance durability and reduce inventory stock levels. It replaces the original dual winding with a single winding using larger wire. This design allows ALL of the Yellow (Brown/Yellow) wires to be connected together and ALL of the Blue (Brown/Blue) wires to be connected together from the stator, permitting the stator to be used for the 2, 3, 4 and 5 cylinder applications.

## Installation

### 2 Cylinder

Replace the original stator with the new one, matching wire colors (Some of these systems use brown/blue for blue and brown/yellow for yellow). Connect all of the Yellow (Brown/Yellow) wires to the Yellow wire from the pack and all of the Blue (Brown/Blue) wires to the Blue wire from the pack.

### 3 Cylinder

Replace the original stator with the new one. Connect all the wires on the new stator to both packs. (Like on a four cylinder engine).

### 4 Cylinder

Replace the original stator with the new one, matching wire colors (Some of these systems use brown/blue or brown/black/blue for blue and brown/yellow or brown/black/yellow for yellow).

### 5 Cylinder

Replace the original stator with the new one, matching wire colors (Some of these systems use brown/blue or brown/black/blue for blue and brown/yellow or brown/black/yellow for yellow). Install the supplied jumper wire from the #2 Brown/Yellow wire to the Brown/Yellow wire for the #3 cylinder. If the original stator had a 2 pin plug on the battery charge wires, remove it from the old stator. Cut the ring terminals from the new stator and use butt splice connectors to connect the plug to the new stator's battery charge wires.

## Troubleshooting

### No fire on any cylinder:

1. Check the resistance from each blue to the yellow wires, you should read approximately 300 ohms.
2. Check the resistance from each blue and yellow wires to engine ground, you should read open circuit (Just like the leads were not touching anything).
3. Check DVA (Peak voltage) from blue to the yellow wires, you should read at least 180V.
4. Disconnect the stator wires and check the DVA (Peak voltage) from each blue and yellow wire to engine ground, you should read no voltage or extremely low voltage.

### No fire on one cylinder:

1. Check the resistance from the blue to the yellow wire on the pack not firing, you should read approximately 300 ohms. If the resistance is not right, check the other set of wires. If the other set is ok, gently pull on the wires close to the connector. If the insulation stretches, the wire is broken inside the insulation and a new terminal needs to be put on.
2. Check DVA (Peak voltage) from the blue to the yellow wire, you should read at least 180V.

### NO FIRE ON TWO CYLINDERS:

If two cylinders from the same CD unit will not fire, the problem is usually in the stator. Test per no fire any cylinder above. If the #1 and #3 cylinders are not firing, disconnect the Brown/Yellow wire from the pack #1 and retest. If you now get fire on #3, replace the #1 pack. If still no fire on #3, disconnect the Brown/Yellow wire from the pack #2 and retest. If you now get fire on #1, replace the #2 pack. If the #2 and #4 cylinders are not firing, disconnect the Brown/Blue wire from the pack #1 and retest. If you now get fire on #4, replace the #1 pack. If still no fire on #4, disconnect the Brown/Blue wire from the pack #2 and retest. If you now get fire on #2, replace the #2 pack.

## 2 & 3 Cylinder Connections:

### Color Code Cross Reference

FUNCTION	OLD	NEW
Trigger	Orange	White/Orange Stripe
Trigger	Green	White/Yellow Stripe
Trigger	Red	White/Red Stripe
Trigger	White/Green Stripe	White/Green Stripe

### Pack #1 (Firing #1 and #2 cylinders)

Trigger: Orange (White/Orange)	Pack: White/Orange Stripe
Green (White/Yellow Stripe)	White/Yellow Stripe
Red (White/Red)	White/Red stripe
White/Green Stripe	White/Green Stripe
Stator: Yellow (Brown/Yellow Stripe)	Pack: Brown/Yellow Stripe
Blue (Brown/Blue Stripe)	Pack: Brown/Blue Stripe
Coil #1: White (Orange/Blue Stripe)	Pack: Orange/Blue Stripe
Coil #2: White (Orange/Blue Stripe)	Pack: Blue/Red stripe

### Color Code Cross Reference

FUNCTION	OLD	NEW
Stator	Blue	Brown/Blue Stripe
Stator	Yellow	Brown/Yellow Stripe
Ignition Coil	White	Orange/Blue
Stop (Kill) Circuit	White (Brown)	Black/Yellow

### Pack #2 (Firing #3 cylinder)

Trigger: Orange (White/Orange)	Pack: White/Orange Stripe
Green (White/Yellow Stripe)	White/Yellow Stripe
No Connection	White/Red Stripe
No Connection	White/Green Stripe
Stator: Yellow (Brown/Yellow Stripe)	Pack: Brown/Yellow Stripe
Blue (must be connected to the Brown/Blue stripe on pack 1)	
Coil #3: White (Orange/Blue Stripe)	Pack: Orange/Blue Stripe

## 4 Cylinder Connections:

### Pack #1 (Firing #1 and #2 cylinders)

Trigger: Orange (White/Orange)	Pack: White/Orange Stripe
Green (White/Yellow Stripe)	White/Yellow Stripe
Red (White/Red)	White/Red stripe
White/Green Stripe	White/Green Stripe
Stator: Yellow (Brown/Yellow Stripe)	Pack: Brown/Yellow Stripe
Blue (Brown/Blue Stripe)	Pack: Brown/Blue Stripe
Coil #1: White (Orange/Blue Stripe)	Pack: Orange/Blue Stripe

### Pack #2 (Firing #3 and #4 cylinders)

Trigger: Orange (White/Orange)	Pack: White/Orange Stripe
Green (White/Yellow Stripe)	White/Yellow Stripe
Red (White/Red)	White/Red Stripe
White/Green Stripe	White/Green Stripe
Stator: Yellow (Brown/Yellow Stripe)	Pack: Brown/Yellow Stripe
Blue (Brown/Blue Stripe)	Pack: Brown/Blue Stripe
Coil #3: White (Orange/Blue Stripe)	Pack: Orange/Blue Stripe

Coil #2: White (Orange/Blue Stripe)

Pack: Blue/Red stripe

Coil #4: White (Orange/Blue Stripe)

Pack: Blue/Red stripe

## 5 Cylinder Connections:

### Pack #1 (Firing #1 and #2 cylinders)

Trigger: Orange (White/Orange)  
Green (White/Yellow Stripe)  
Red (White/Red)  
White/Green Stripe

Pack: White/Orange Stripe  
White/Yellow Stripe  
White/Red stripe  
White/Green Stripe

Stator: Yellow (Brown/Yellow Stripe)  
Blue (Brown/Blue Stripe)

Pack: Brown/Yellow Stripe  
Pack: Brown/Blue Stripe  
Pack: Orange/Blue Stripe  
Pack: Blue/Red stripe

Coil #1: White (Orange/Blue Stripe)

Coil #2: White (Orange/Blue Stripe)

### Pack #3 (Firing #3 and #4 cylinders)

Trigger: Orange (White/Orange)  
Green (White/Yellow Stripe)  
Red (White/Red)  
White/Green Stripe

Pack: White/Orange Stripe  
White/Yellow Stripe  
White/Red stripe  
White/Green Stripe

Stator: Yellow (Brown/Yellow Stripe)  
Blue (Brown/Blue Stripe)

Pack: Brown/Yellow Stripe  
Pack: Brown/Blue Stripe  
Pack: Orange/Blue Stripe  
Pack: Blue/Red stripe

Coil #3: White (Orange/Blue Stripe)

Coil #4: White (Orange/Blue Stripe)

### Pack #2 (Firing #5 cylinder)

Trigger: Orange (White/Orange)  
Green (White/Yellow Stripe)  
No Connection  
No Connection

Pack: White/Orange Stripe  
White/Yellow Stripe  
White/Red Stripe  
White/Green Stripe

Stator: Yellow (Brown/Yellow Stripe)  
Blue (must be connected to the Brown/Blue stripe on pack 1)

Coil #5: White (Orange/Blue Stripe)

Pack: Orange/Blue Stripe

NOTICE: The color codes listed above may appear on the packs, stators or triggers. Some packs have solid colors and some triggers have striped wires. If you need further assistance, please call our technical support department.

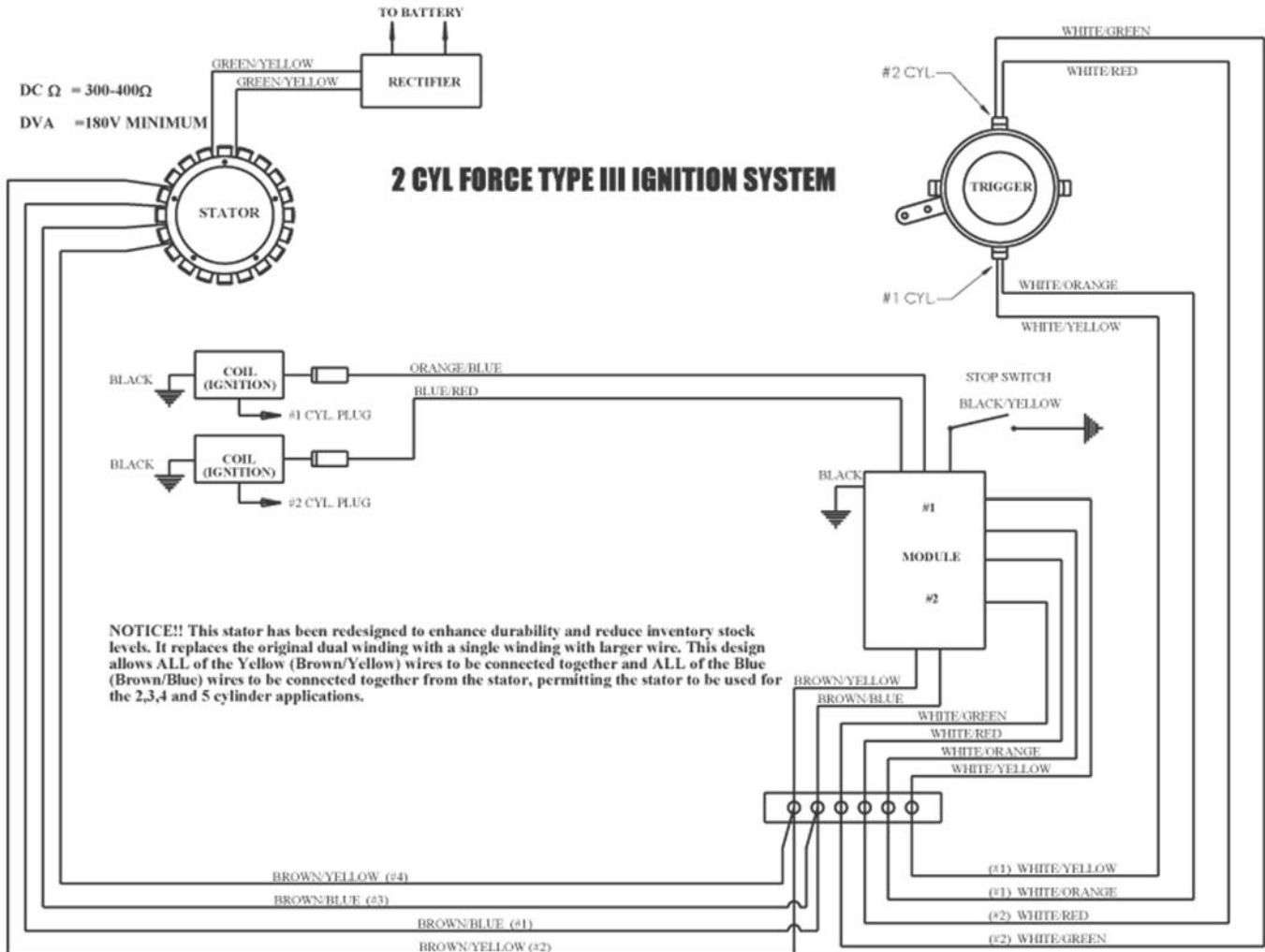

# Installation and Troubleshooting Guide

All rights reserved. Reproduction or use of content, in any manner, without express written permission by CDI Electronics, Inc., is prohibited.

The following wiring diagrams are for reference when using the CDI Electronics triggers:

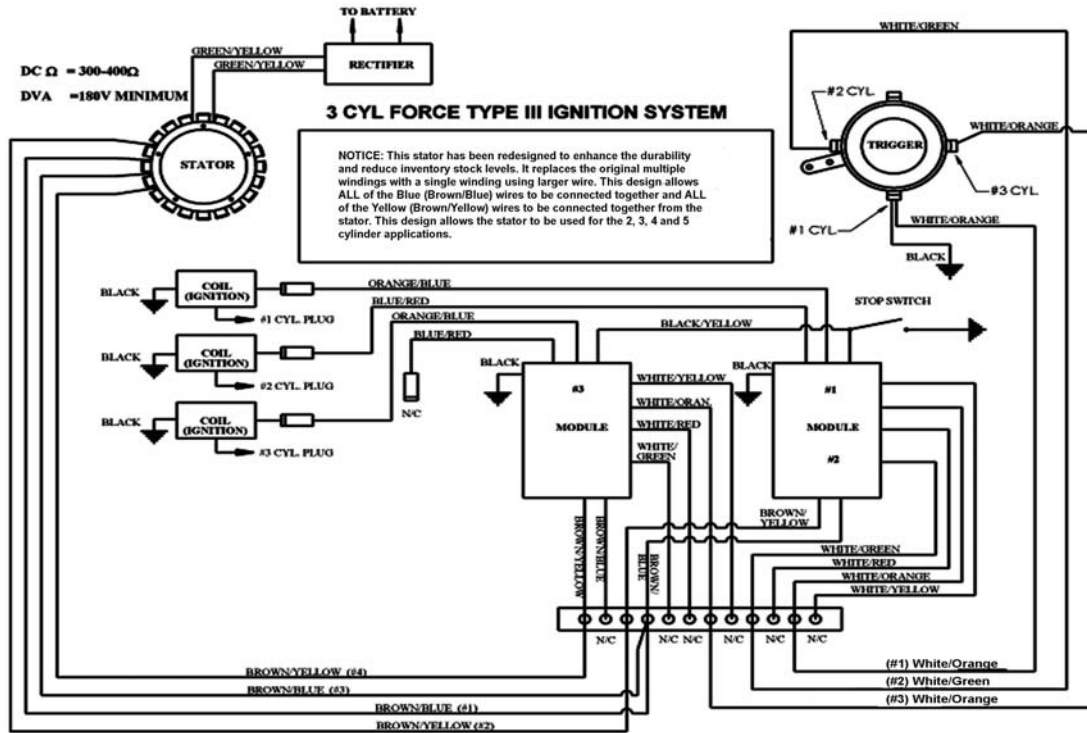

USING OEM TRIGGER AND CDI STATOR

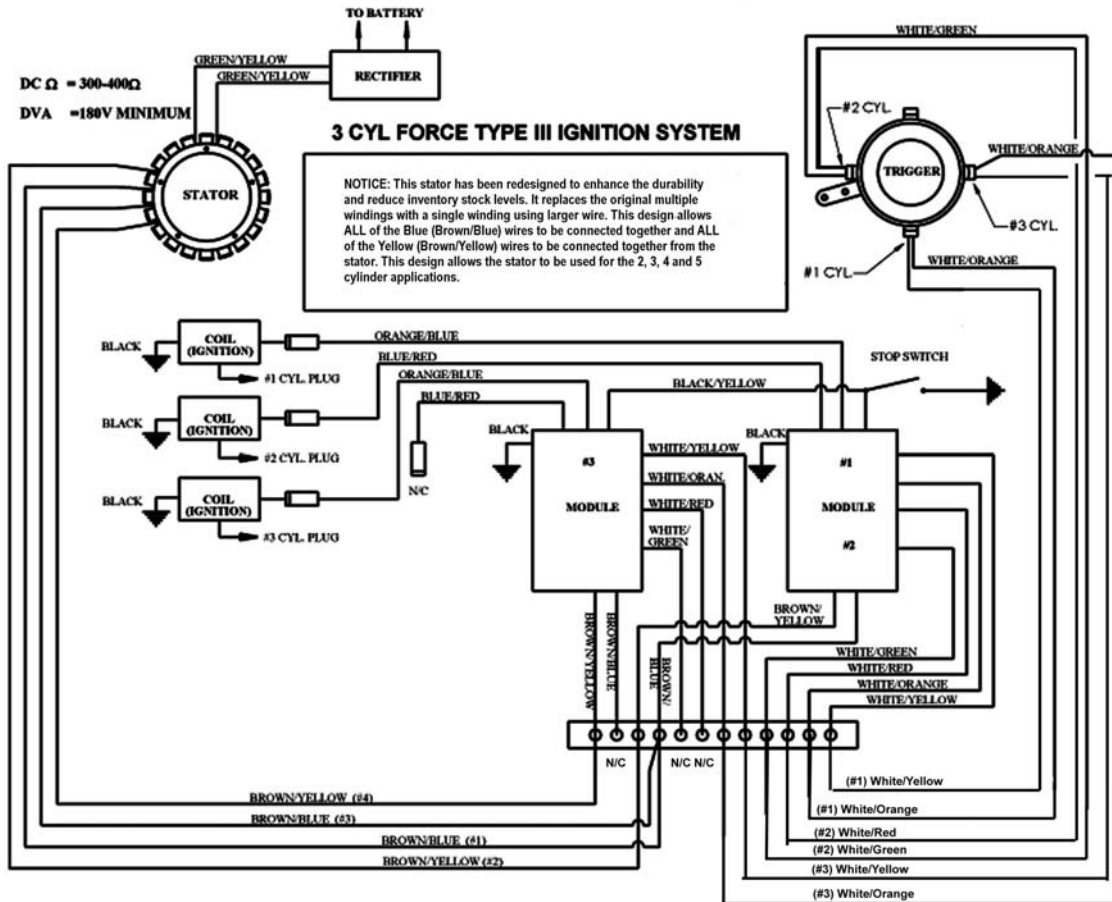



# Installation and Troubleshooting Guide

All rights reserved. Reproduction or use of content, in any manner, without express written permission by CDI Electronics, Inc., is prohibited.

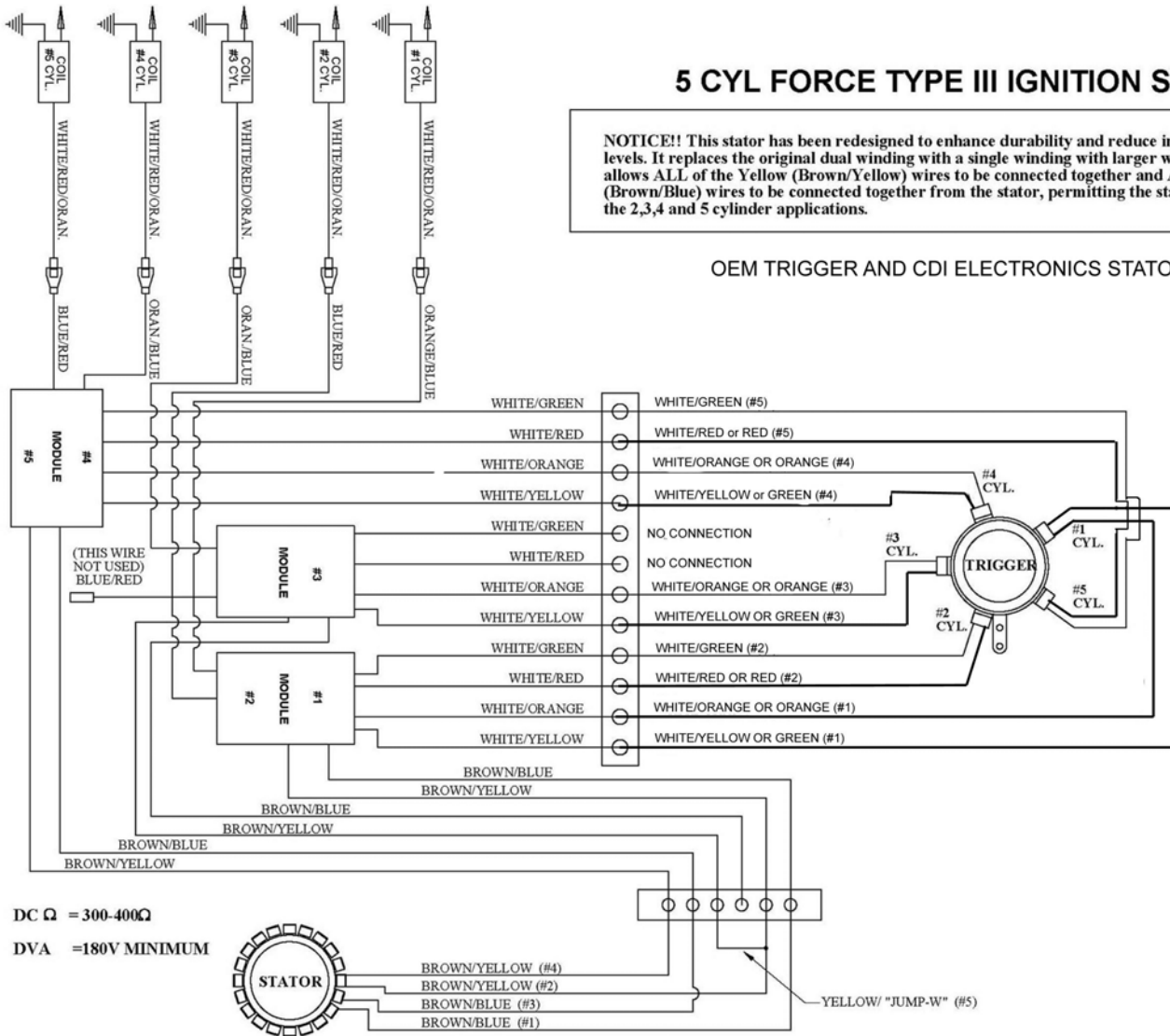

# Installation and Troubleshooting Guide

All rights reserved. Reproduction or use of content, in any manner, without express written permission by CDI Electronics, Inc., is prohibited.

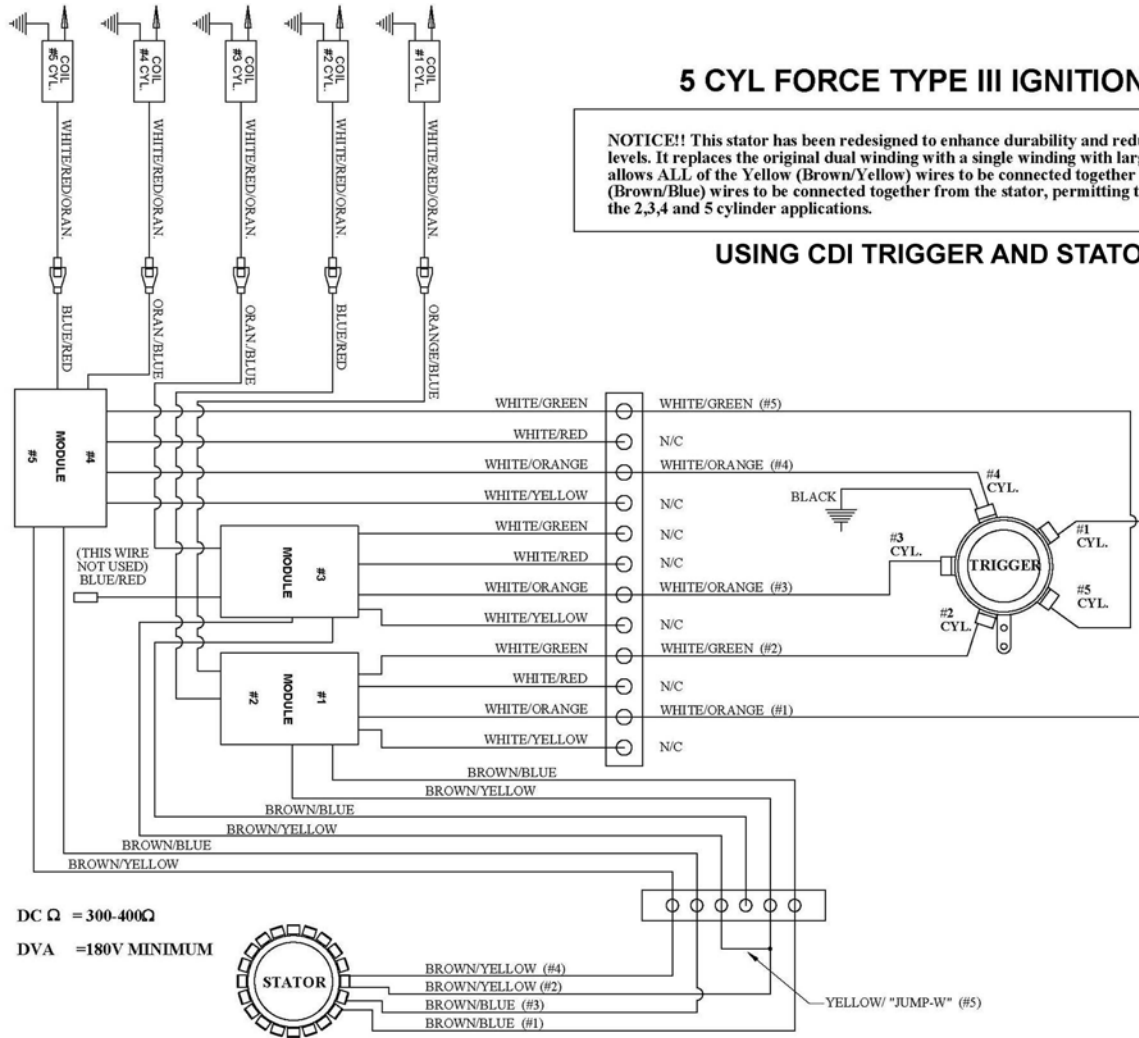

Thank you for using CDI Electronics.

6/5/2009